

SafeFloor Connect 2422

Wireless Floor sensor



Field of application

The SafeFloor Connect wireless floor sensor is used for critical and/or particularly special monitoring applications. If the smart sensor registers

something outside the set parameters it gives and a warning tone and reports this to your smartphone or tablet.

Design

The SafeFloor Connect's monitoring electronics allow leaks, a too low room temperature or a too high humidity to be detected. If the pre-programmed values are exceeded, a warning tone and reports this to your smartphone or tablet. If a SafeTech Connect is installed, the drinking water line is shut-

off. Several SafeFloor Connect sensors can be used. With the help of the SafeTech Connect leakage protection, the sensors can be managed. In this case the SafeTech Connect works as a control centre, registers the received data and becomes active accordingly

Materials

The body is made of synthetic material. All materials used are state-of-the-art. The synthetic and elastomeric parts in contact with water are approved by the German Public Health Office (KTW).

Installation

The SafeFloor Connect is placed on the floor. Place the sensor or the sensors at endangered places of your choice.

Technical specifications

Standard wireless protocol	WiFi 2,4 Ghz WPA / WPA2 protected
Batteries	3 x LR03 (AAA)
Protection class:	CE-approved
Serial number:	2422.00.000

Maintenance

The batteries have to be changed every 2 years

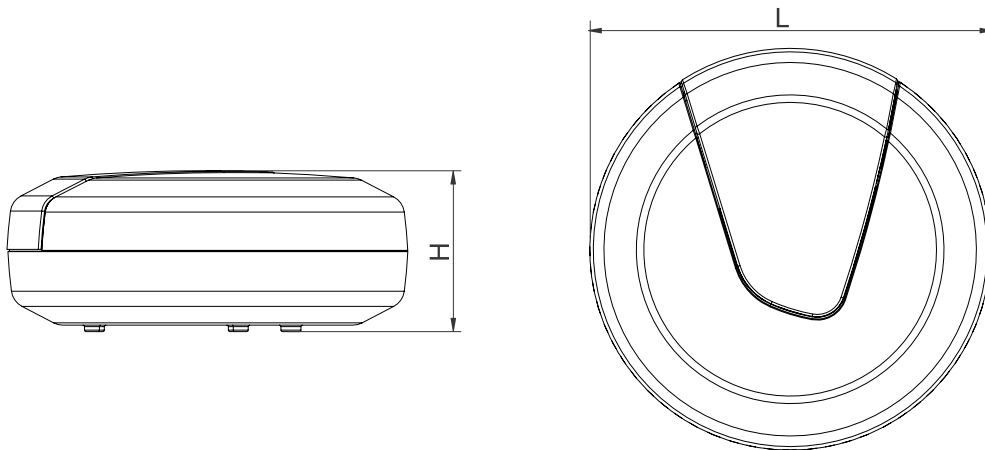

Dimensions	H (mm)	32.2
	L (mm)	80

Components / Order numbers

①
Batteries

