

Contents

DK Indholdsfortegnelse	LT Turinys	PL Spis treści	UA Зміст
EE Sisukord	LV Saturs	RU Содержание	
FI Sisällysluettelo	NO Innhold	SE Innehållsförteckning	

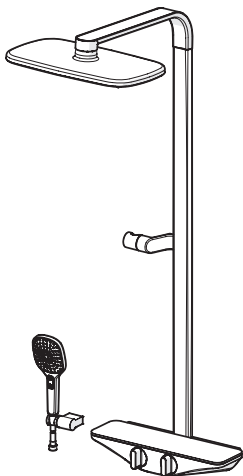

Technical data.....	4-5
Installation	8-13
Operation.....	14-16
Maintenance.....	18-22, 27
Spare parts.....	28

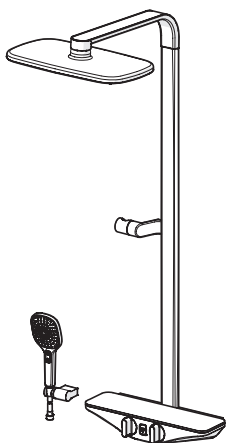

Technical data.....	6-7
Installation	8-13
Operation.....	14-17
Maintenance.....	18-27
Spare parts.....	29-30



Oras App



apps.oras.com

Apple and the Apple logo are trademarks of Apple Inc., registered in the U.S. and other countries. App Store is a service mark of Apple Inc., registered in the U.S. and other countries.

Google Play and the Google Play logo are trademarks of Google Inc.

The Bluetooth® word mark and logos are registered trademarks owned by the Bluetooth SIG, Inc. and any use of such marks by Oras Group is under license. Other trademarks and trade names are those of their respective owners.

7560-15 , 7560-11

EN 1111
 100 – 1000 kPa
 I (ISO 3822) Oras lab.
 max. +80°C

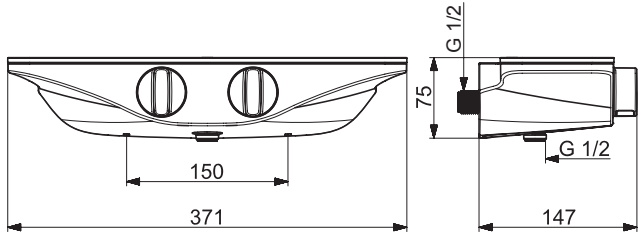

7560U-15 , 7560U-11

EN 1111
 100 – 1000 kPa
 I (ISO 3822) Oras lab.
 max. +80°C

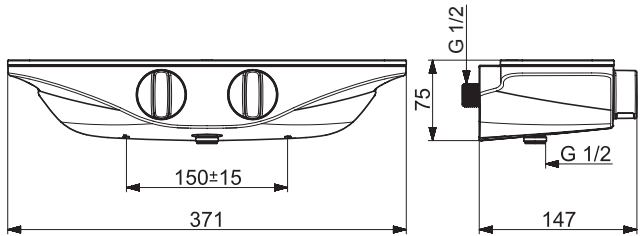

7540-15 , 7540-11

EN 1111
 100 – 1000 kPa
 I (ISO 3822) Oras lab.
 max. +80°C

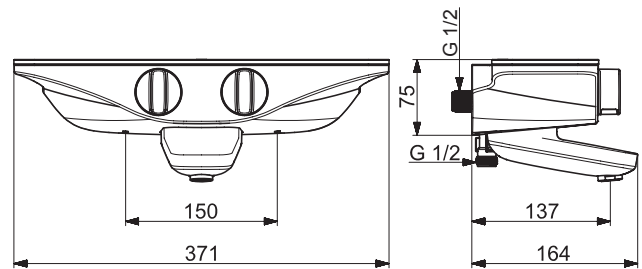

7540U-15 , 7540U-11

EN 1111
 100 – 1000 kPa
 I (ISO 3822) Oras lab.
 max. +80°C

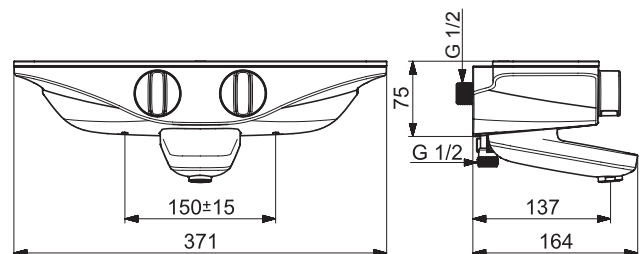

7590-15 , 7590-11

EN 1111

100 – 1000 kPa

I (ISO 3822) Oras lab.

max. +80°C

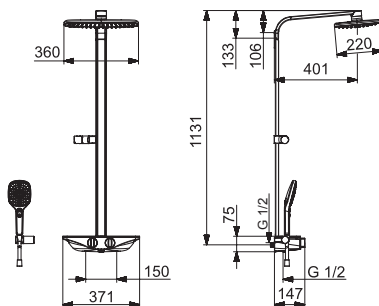

7590U-15 , 7590U-11

EN 1111

100 – 1000 kPa

I (ISO 3822) Oras lab.

max. +80°C

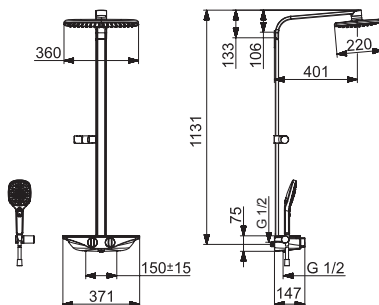

7591-15 , 7591-11

EN 1111

100 – 1000 kPa

I (ISO 3822) Oras lab.

max. +80°C

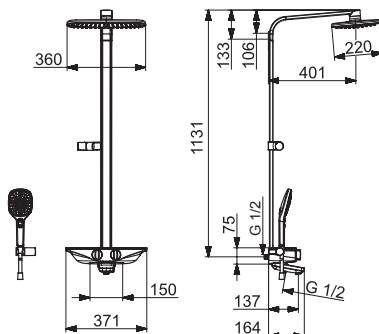

7591U-15 , 7591U-11

EN 1111

100 – 1000 kPa

I (ISO 3822) Oras lab.

max. +80°C

