

UNICO

INVERTER

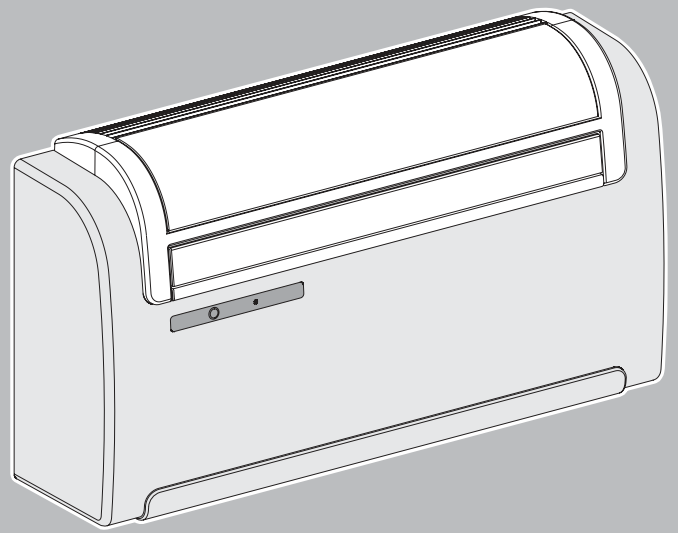

 **OLIMPIA
SPLENDID**
NUOVI SISTEMI USER FRIENDLY

ISTRUZIONI PER INSTALLAZIONE, USO E MANUTENZIONE **I**

INSTRUCTIONS FOR INSTALLATION, USE AND MAINTENANCE **GB**

INSTRUCTIONS POUR L'INSTALLATION, L'EMPLOI ET L'ENTRETIEN **F**

HANDBUCH FÜR INSTALLATION, GEBRAUCH UND WARTUNG **D**

INSTRUCCIONES PARA LA INSTALACIÓN, USO Y MANTENIMIENTO **E**

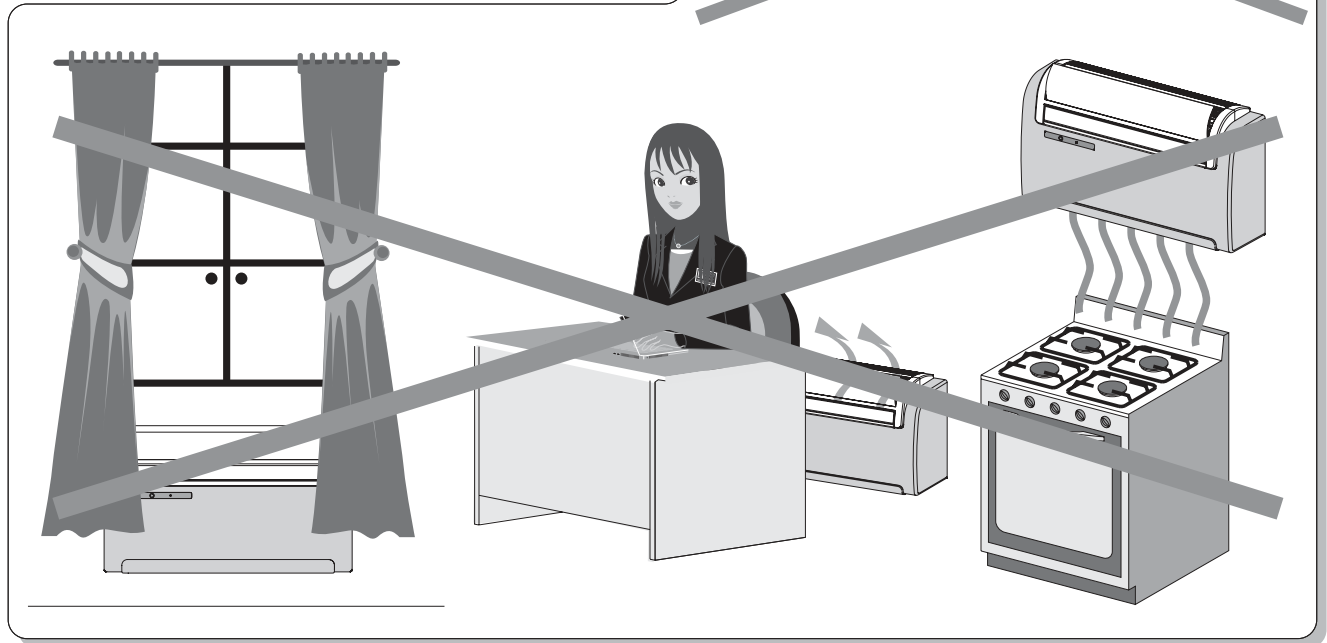
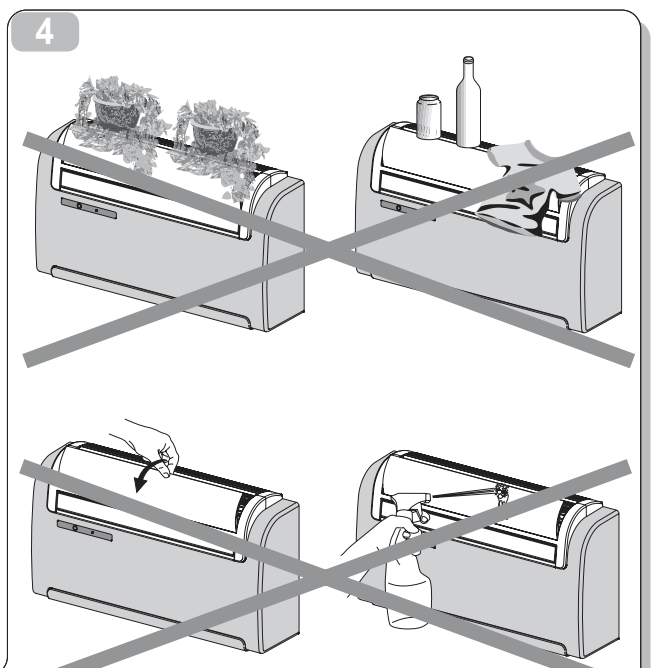
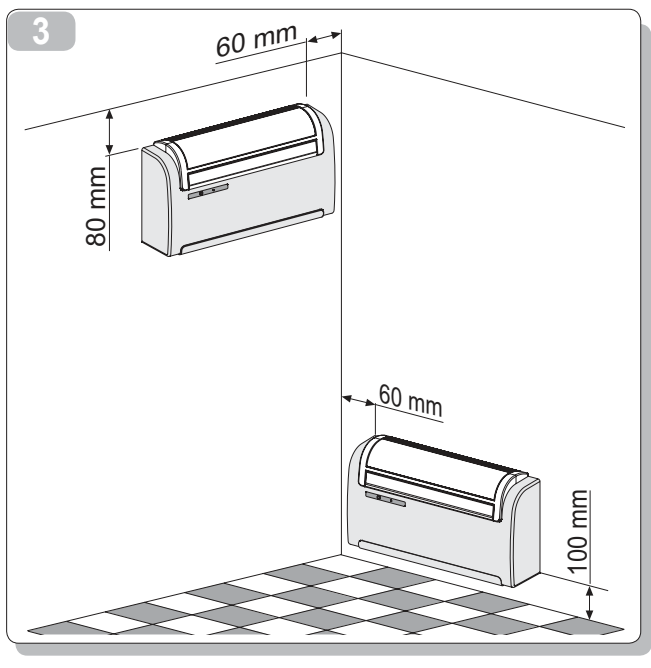
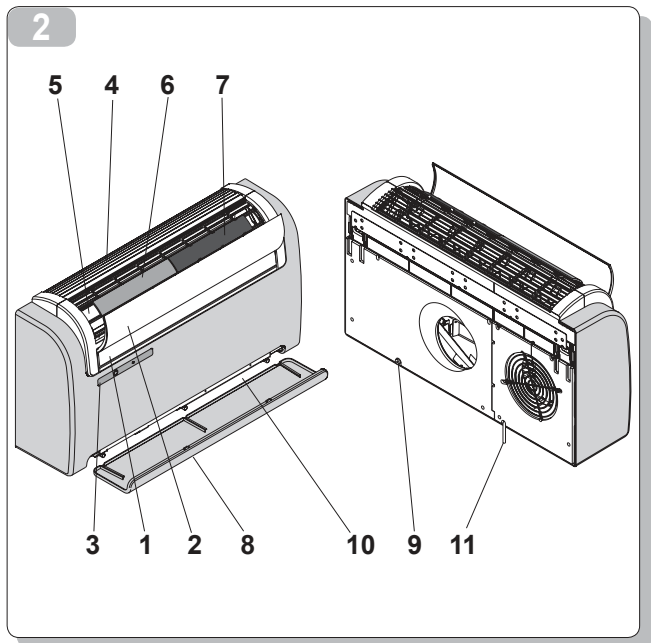
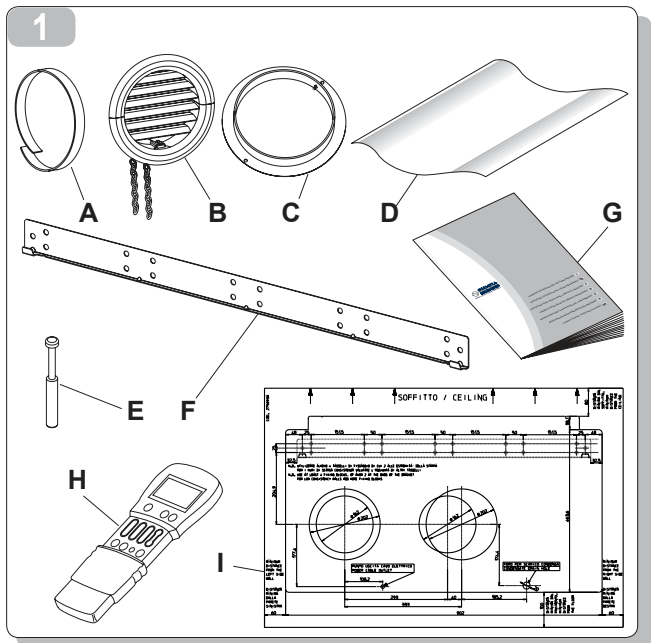

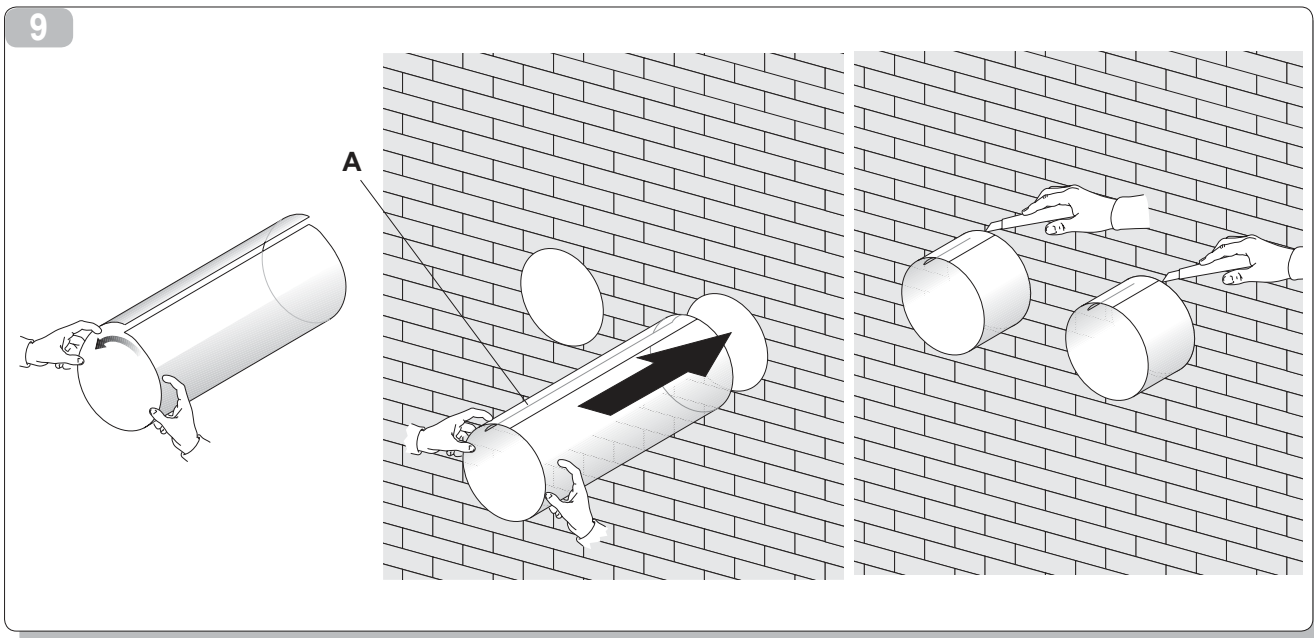
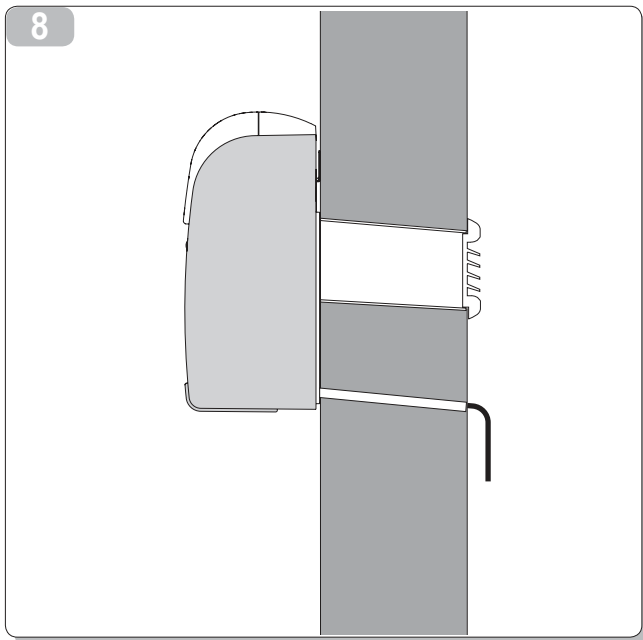
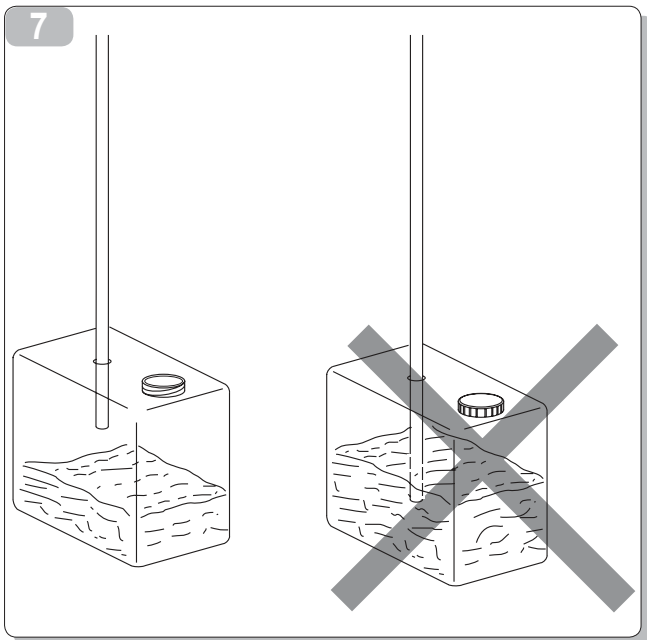
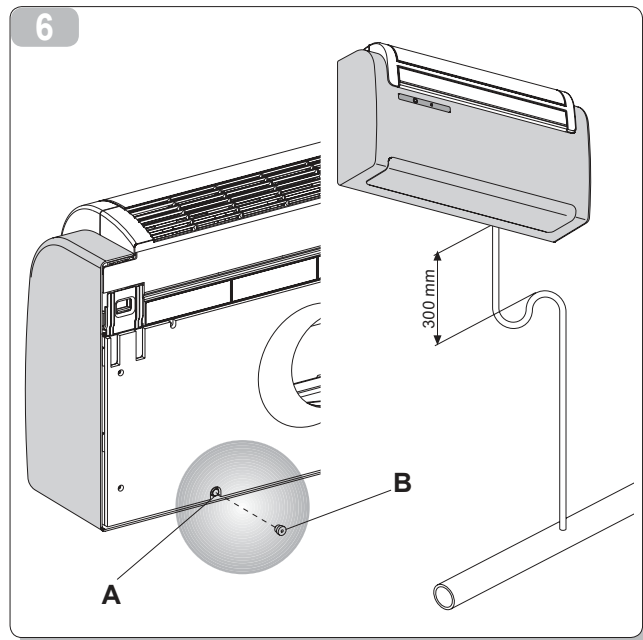
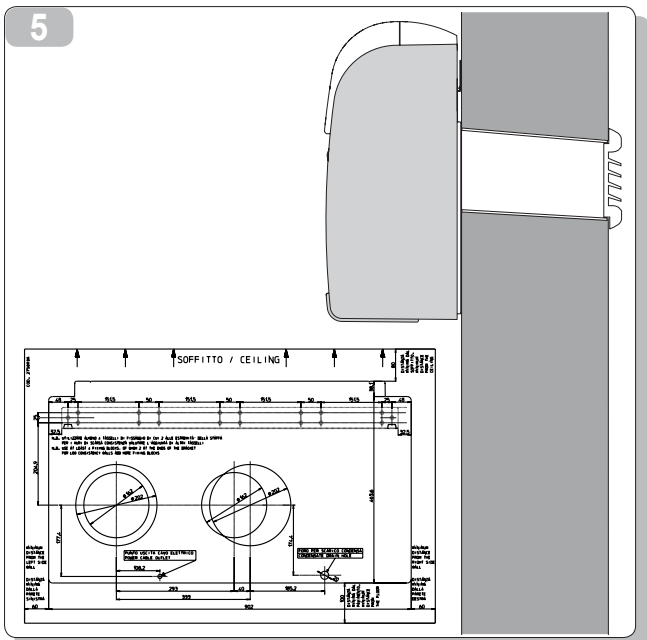

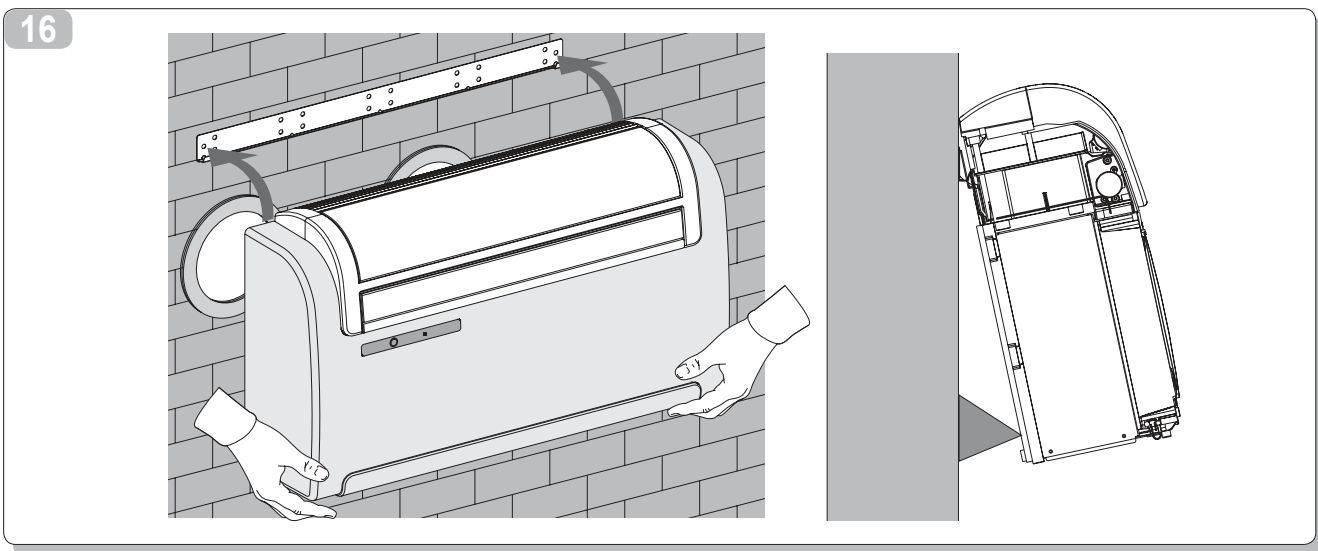
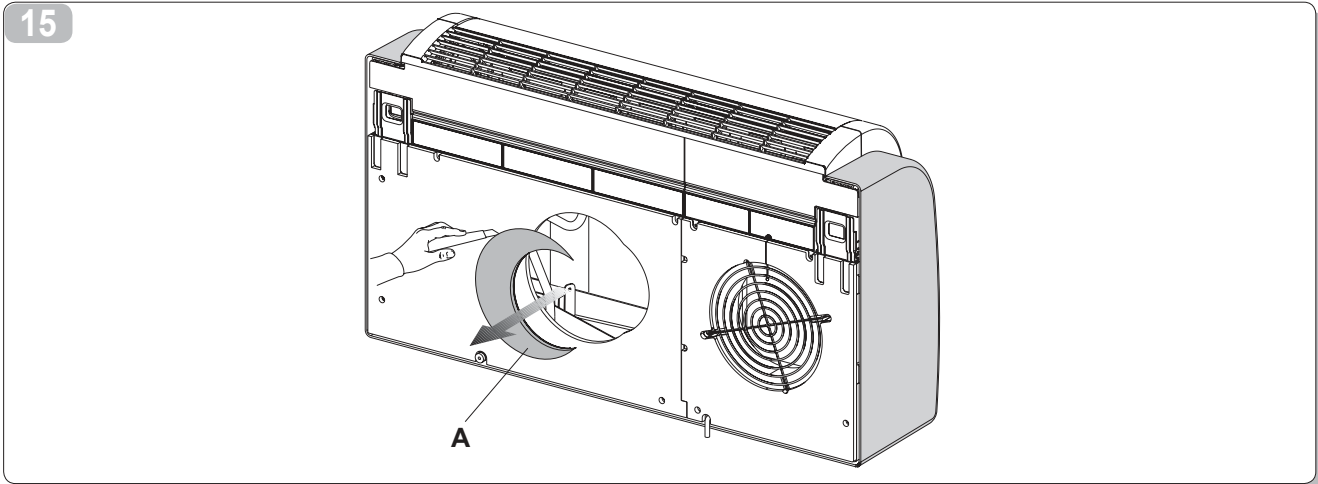
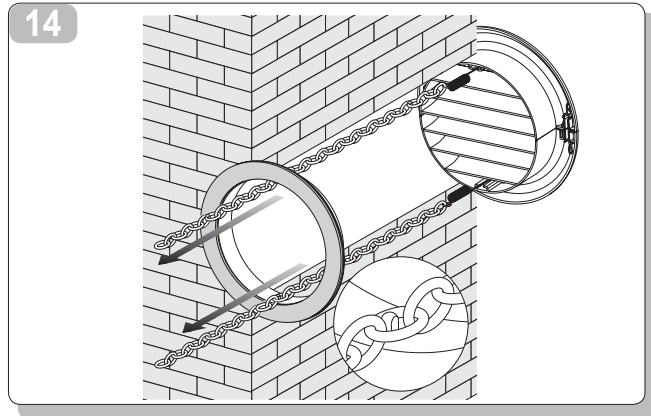
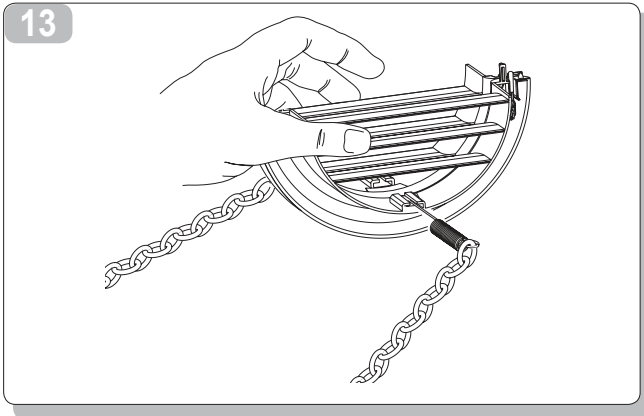
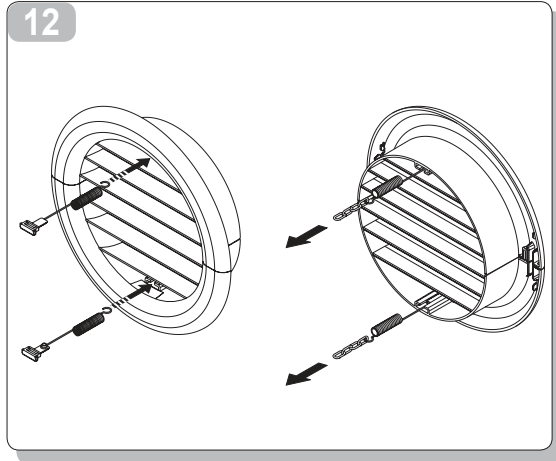
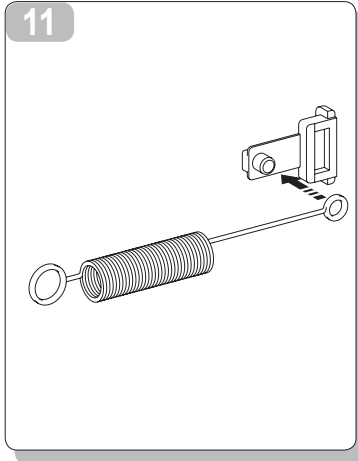
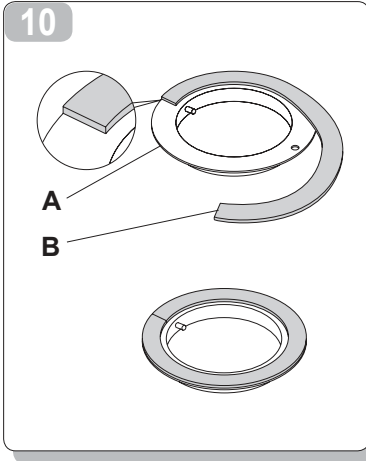

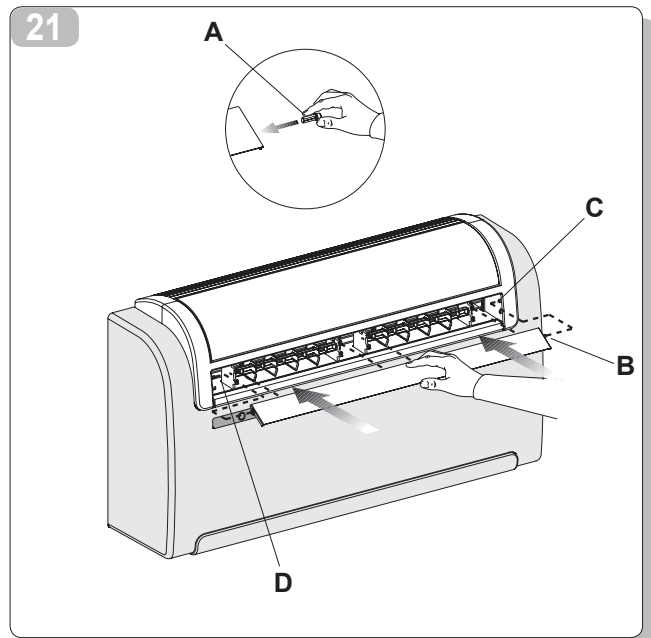
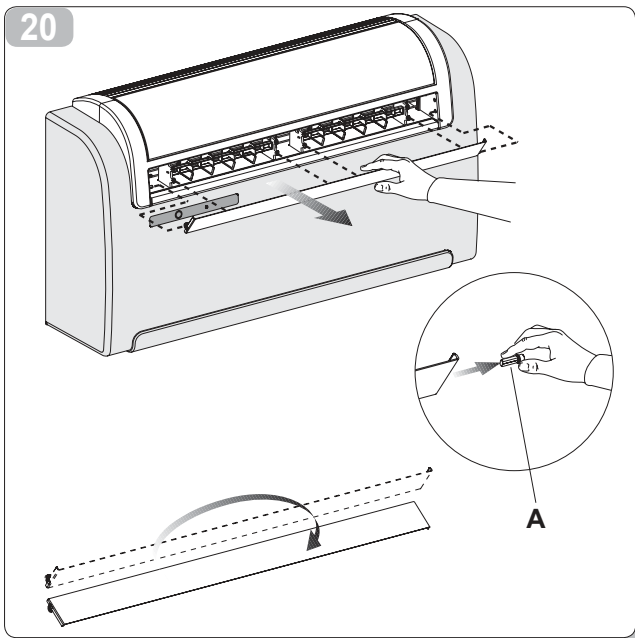
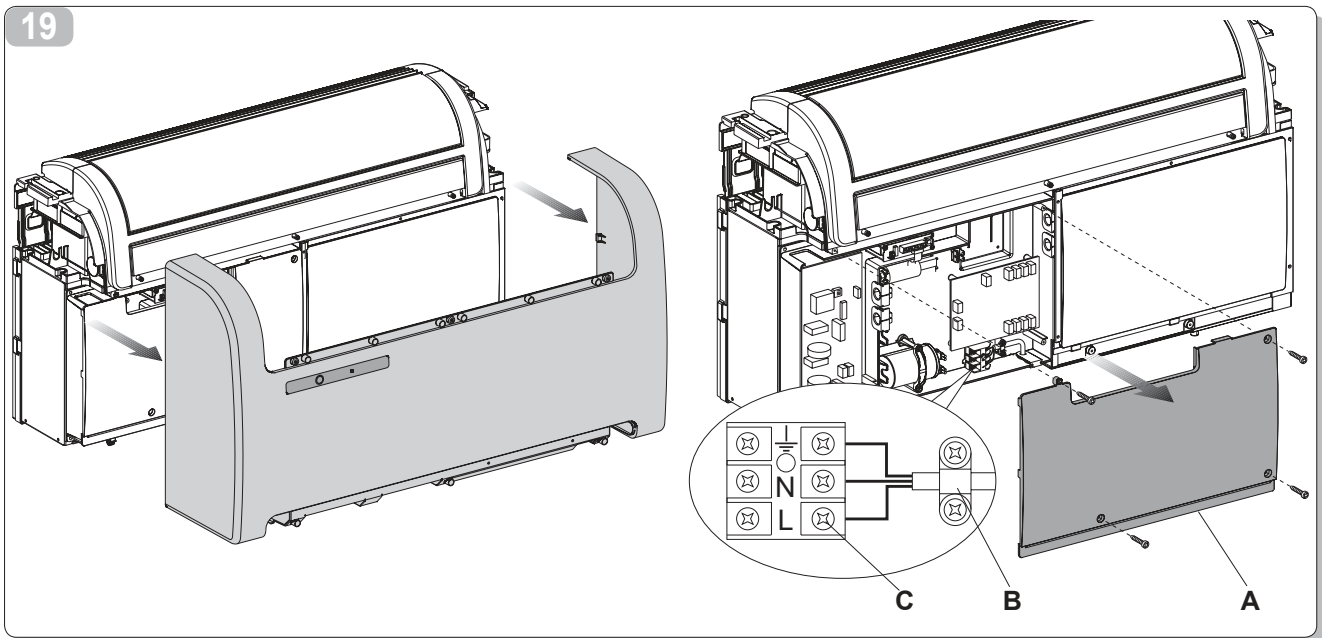
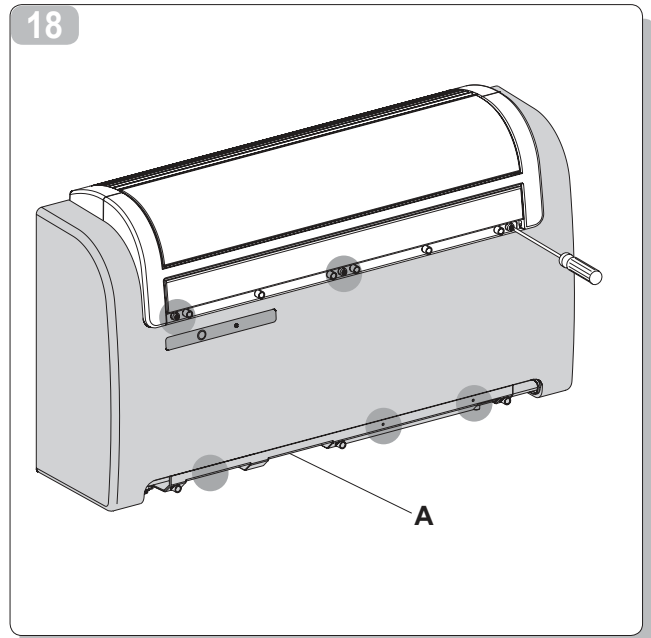
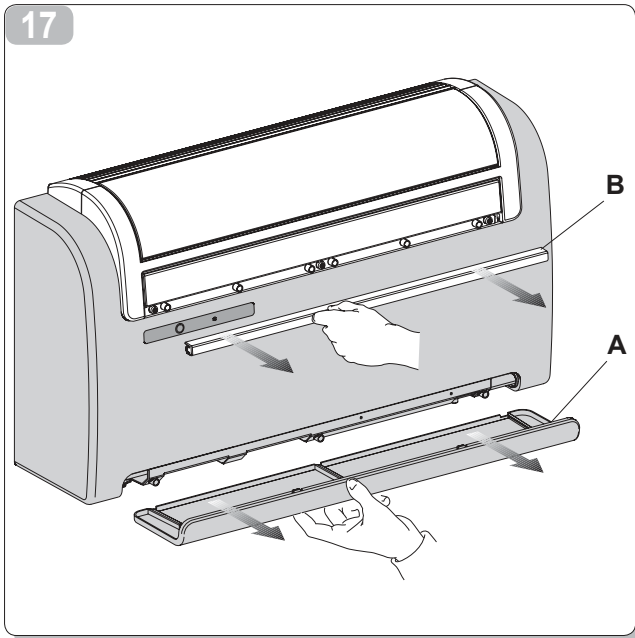

22

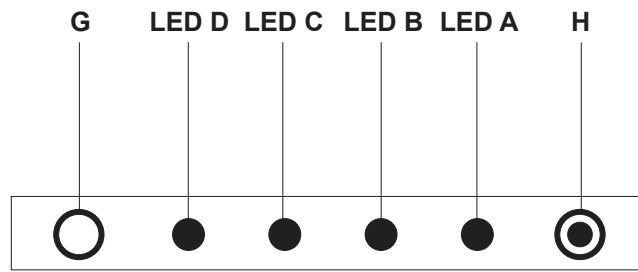

23

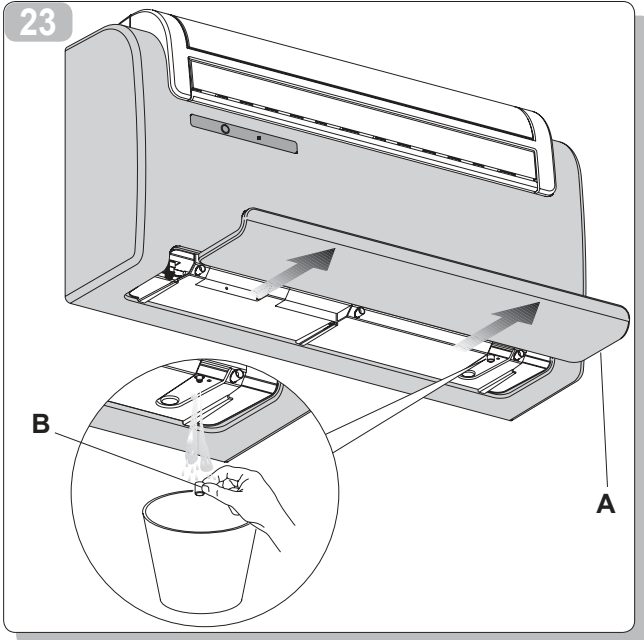

24

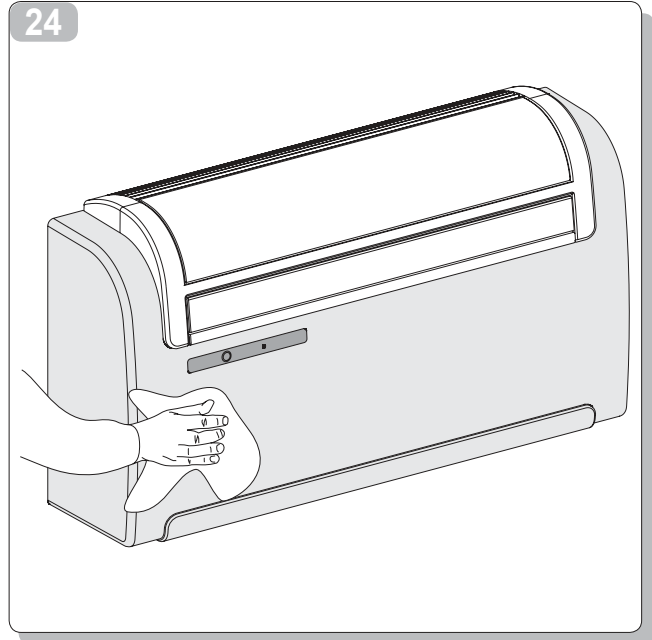

25

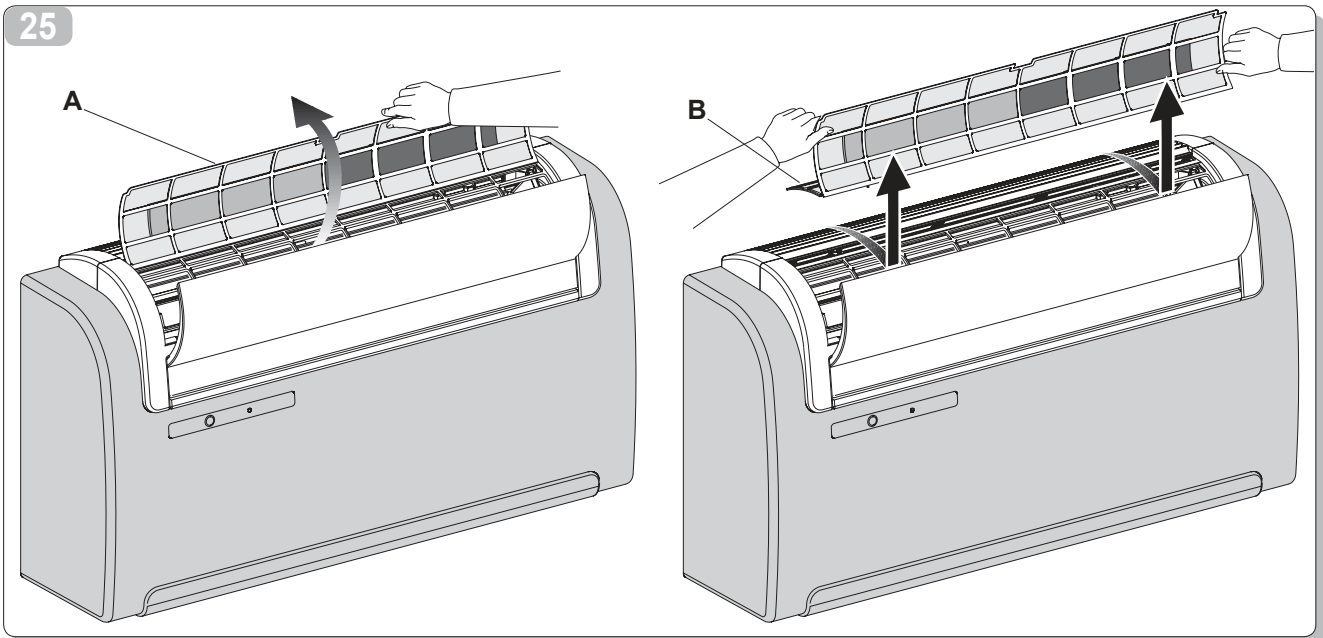

26

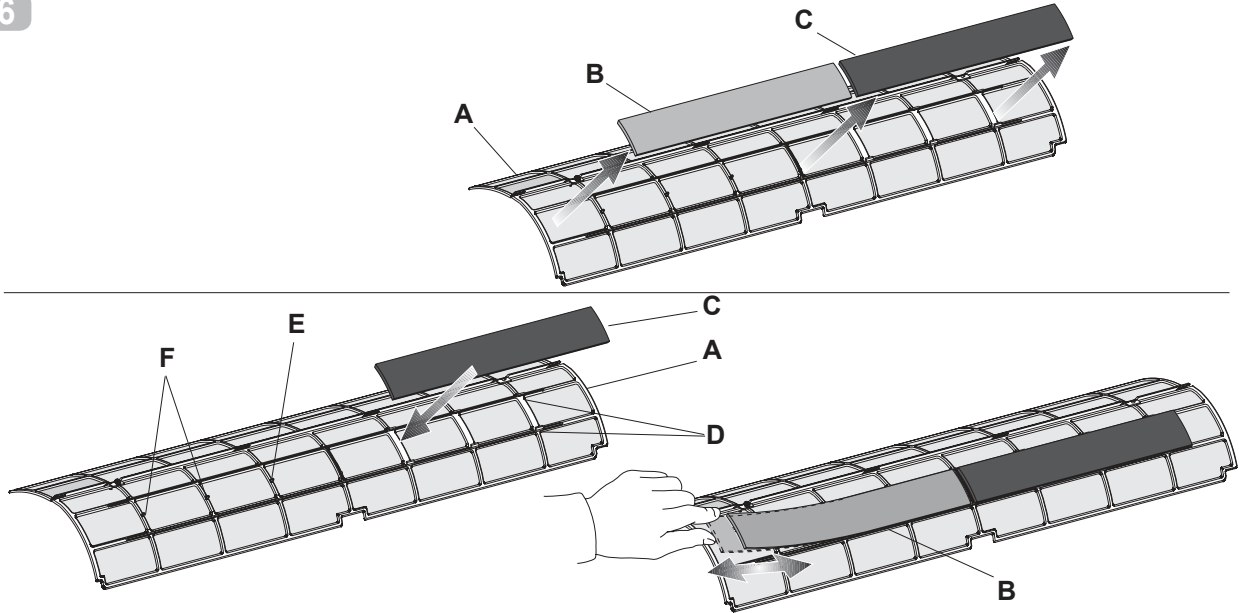

27

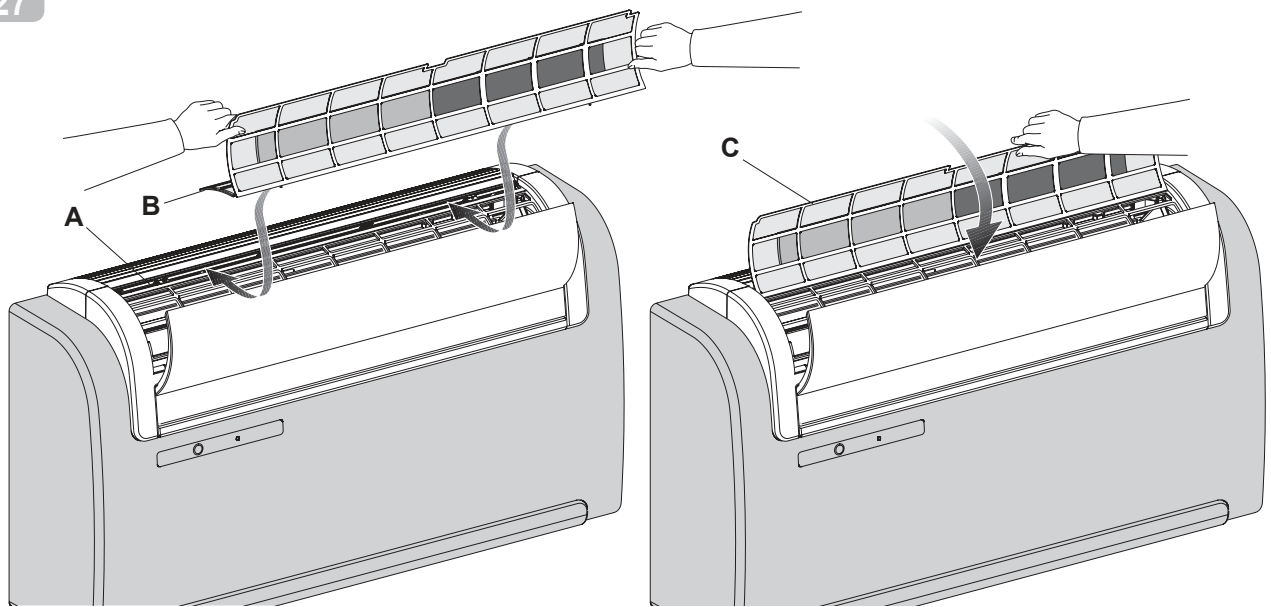

28

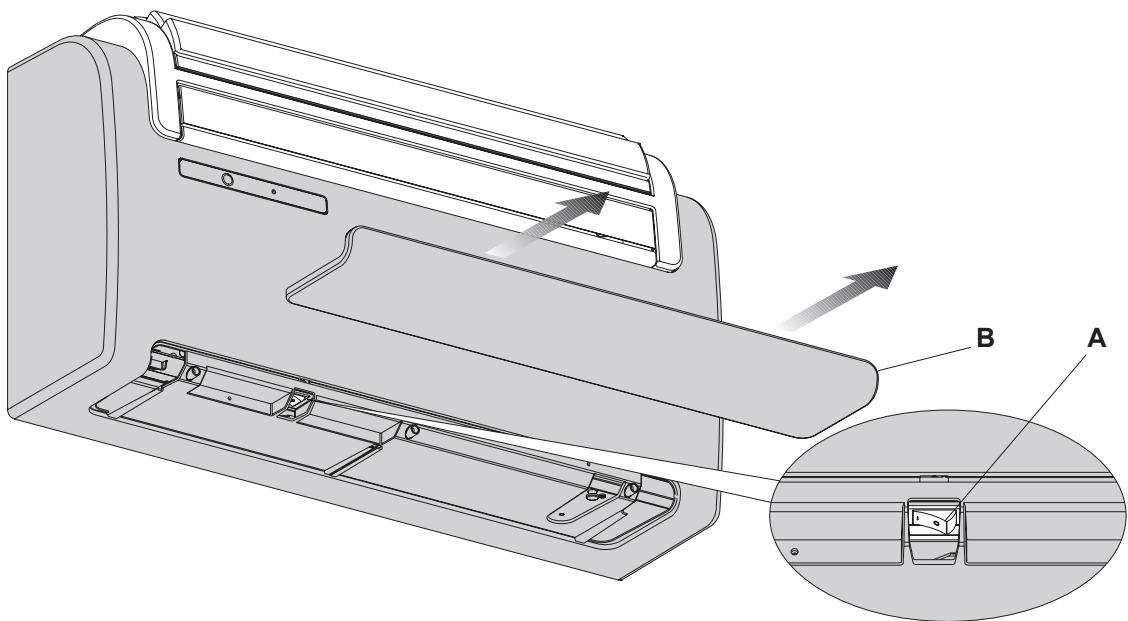

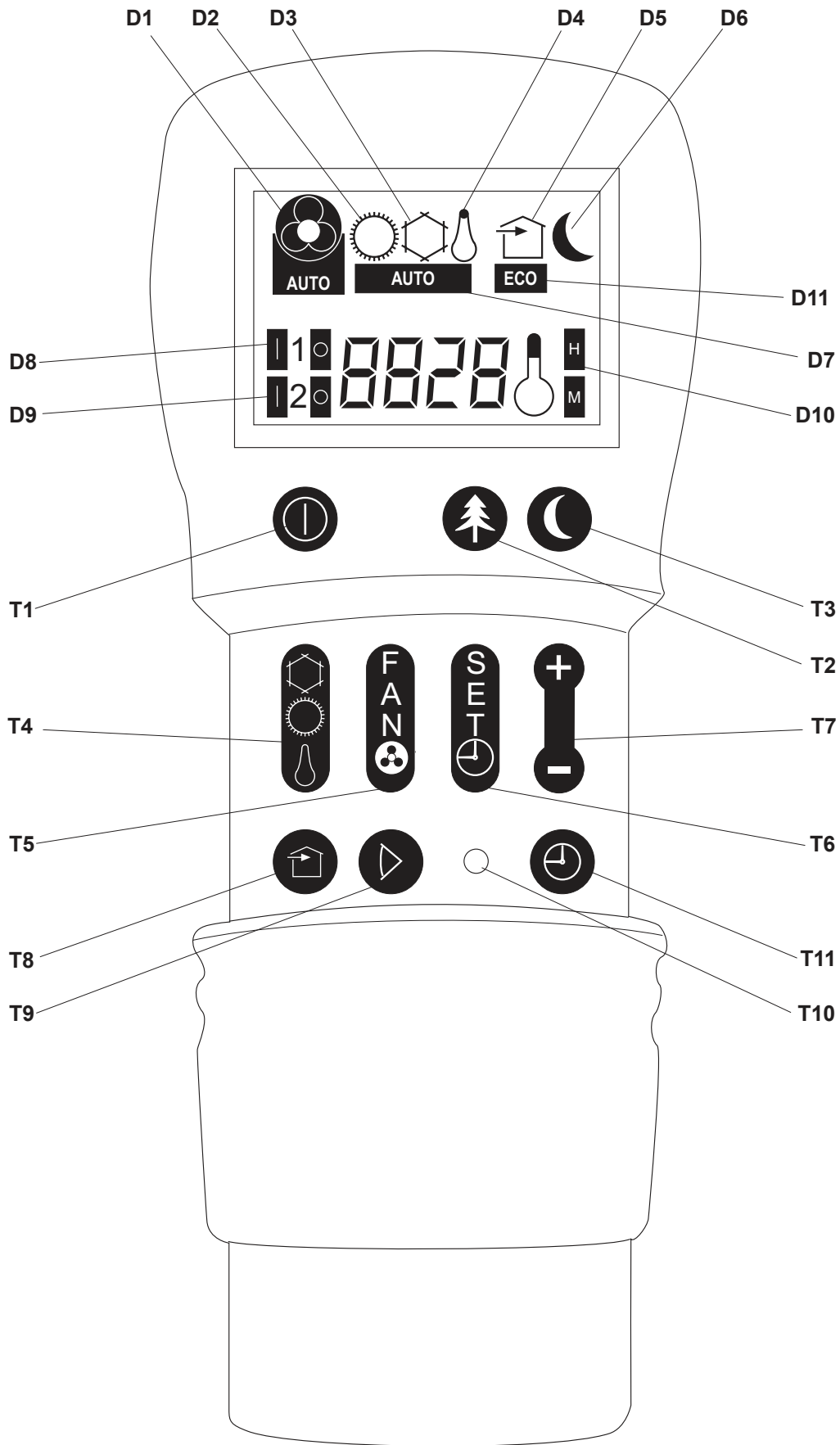

WARNINGS

1. The appliance may be used by children over 8 years of age and by persons with reduced physical, sensorial or mental capacities, or without the required experience or knowledge, provided they are supervised or have been instructed in the safe use of the appliance and understand the hazards involved.
2. Children must not play with the equipment.
3. Children must not be allowed to clean the appliance or perform user maintenance without proper supervision.
4. If the power cable is damaged, it must be replaced by the manufacturer or by its technical support service or by similarly qualified personnel, to prevent any risk to the user.
5. Installation, initial start-up and subsequent maintenance, with the exception of the ambient air filter cleaning and washing, must be carried out solely by authorised and qualified personnel.
6. To prevent the risk of an electric shock it is mandatory to switch off the main switch before performing the electrical connections or any maintenance operation to the appliances.
7. During installation, comply with the minimum clearances shown in Figures 3, 4, 5
8. During the appliance electrical connection, following the indications shown in Fig. 23A and 23B.

1	GENERAL	
1.1	SYMBOLS	26
1.1.1	Editorial pictograms	26
1.1.2	Safety pictograms	26
1.2	GENERAL INFORMATION	26
1.3	WARNING	27
1.4	LIST OF SUPPLIED COMPONENTS	27
1.4.1	Storage	28
1.4.2	Receipt and unpacking	28
1.5	UNIT ELEMENTS	28
2	INSTALLATION	
2.1	INSTALLATION MODES	29
2.1.1	Size and specifications of the room in which to install the air conditioner	29
2.2	CHOOSING THE POSITION OF THE UNIT	29
2.3	Unit assembly	29
2.3.1	Warning	29
2.3.2	Drilling the wall	29
2.3.3	Preparing the condensate discharge	30
2.3.4	Assembly of the air ducts and external grids	30
2.3.5	Preparing the holes on the machine	31
2.3.6	Fitting the unit on the bracket	31
2.3.7	Electric hook-up	31
2.4	TOP/BOTTOM INSTALLATION CONFIGURATION	32
2.5	TESTS AND TROUBLESHOOTING	32
2.5.1	Evacuating condensate water during an emergency	33
2.6	ROUTINE MAINTENANCE	33
2.6.1	Cleaning the air filter	33
3	USE AND MAINTENANCE (user part)	
3.1	WARNINGS	34
3.1.1	Description of the warning panel	34
3.2	MANAGING THE UNIT WITH THE REMOTE CONTROL	34
3.2.1	Remote control	34
3.2.2	Fitting the batteries	34
3.3	REMOTE CONTROL	35
3.3.1	Description of the remote control	35
3.3.2	Main switch-on and running management	35
3.3.3	Turning the unit ON/OFF	35
3.3.4	ECO key	35
3.3.5	Cooling	36
3.3.6	Dehumidification only	36
3.3.7	Ventilation only	36
3.3.8	Well-being function (automatic)	36
3.3.9	Heating (only models fitted with heating pump)	36
3.3.10	Checking airflow direction	36
3.3.11	Checking fan speed	36
3.3.12	Night well-being key	37
3.3.13	Setting the operating programs	37
3.3.14	Setting the exact time	37
3.3.15	Setting the times of the 1st and 2nd the operating programs (PROGR. 1 and PROGR. 2)	37
3.3.16	Starting and stopping the operating programs	37
3.3.17	Resetting all remote control functions	38
3.3.18	Managing the unit if the remote control is not available	38
3.4	ENERGY SAVING ADVICE	38
3.5	TROUBLESHOOTING	38
3.5.1	Functional aspects not to be interpreted as problems	38
3.5.2	Troubleshooting	39
3.5.3	Specifications	40

GENERAL

1

1.1 SYMBOLS

The pictograms shown in the next chapter provide the information necessary for correct use of the appliance in a rapid and unmistakable way.

1.1.1 Editorial pictograms



Service

- Refers to situations in which you should inform the SERVICE department in the company: **CUSTOMER TECHNICAL SERVICE.**



Index

- Paragraphs marked with this symbol contain very important information and recommendations, particularly as regards safety. Failure to comply with them could result in:
 - danger of injury to the operators
 - loss of the warranty
 - refusal of liability by the manufacturer.



Raised hand

- Refers to actions that absolutely must not be performed.

1.1.2 Safety pictograms



Danger of high voltage

- Signals to the personnel that the operation described could cause electrocution if not performed according to the safety rules.



Generic danger

- Signals to the personnel that the operation described could cause physical injury if not performed according to the safety rules.



Danger from heat

- Signals to the personnel that the operation described could cause burns if not performed according to the safety rules.

1.2 GENERAL INFORMATION

First of all, we would like to thank you for choosing an air-conditioner produced by our company.

We are sure you will be happy with it because it represents the state of the art in home air conditioning technology.

This manual has been compiled with the aim of providing you with all the explanations necessary to manage perfectly your conditioning system.

Therefore, please read the manual carefully before using the equipment.

By following the suggestions contained in this manual, the conditioner that you have purchased will operate without problems giving you optimum room temperatures with minimum energy costs.

The manual is divided into 3 sections or chapters:

CHAP. 1 GENERAL INFORMATION

Aimed at the specialised installer and the end user.

It contains information, **technical data and important warnings** to heed before installing and using the conditioner.

CHAP. 2 INSTALLATION

Aimed **exclusively** at a specialised installer.

It contains all the information necessary for the positioning and mounting of the conditioner in the place where it will be installed.

The installation of the conditioner by non-specialised personnel will invalidate the warranty conditions.

CHAP. 3 USE AND MAINTENANCE (user part)

Contains useful information for understanding the use and programming of the conditioner and the most common maintenance interventions.



This is a legally reserved document and the reproduction or transmission to third parties without the explicit authorisation of **OLIMPIA SPLENDID** is absolutely forbidden.

The appliances could be subject to updating and therefore appear different from the designs contained herein, although this does not in any way invalidate the texts contained in the manual.

Read this manual carefully before performing any operation (installation, maintenance, use) and follow the instructions contained in each chapter.



THE MANUFACTURER IS NOT RESPONSIBLE FOR DAMAGES TO PERSONS OR PROPERTY CAUSED BY FAILURE TO FOLLOW THE INSTRUCTIONS IN THIS MANUAL.

The manufacturer reserves the right to modify at any time its models without changing the fundamental characteristics described in this manual.

The installation and maintenance of air-conditioners like this one may be hazardous as they contain a cooling gas under pressure as well as powered parts.



Therefore, the installation, first startup and subsequent maintenance should be carried out exclusively by authorized, qualified personnel.

Failing to comply with the instructions contained in this manual, and using the unit with temperatures exceeding the permissible temperature range will invalidate the warranty.

Routine maintenance of the filters and general external cleaning can be done by the user as these operations are not difficult or dangerous.

During the assembly and each maintenance operation, always pay attention to the warnings described in this manual and on the labels affixed inside the appliances, and respect anything suggested by common sense and those of the Safety Norms in force in the place of installation.



Always wear gloves and protective goggles when carrying out interventions on the cooling part of the appliance.



Conditioners **MUST NEVER** be installed in rooms where there is inflammable gas, explosive gas, a high level of humidity (laundry rooms, greenhouses etc), or in rooms where there are other machines that generate a lot of heat.



Should components need replacing, always use **OLIMPIA SPLENDID** original spare parts.



IMPORTANT!

To avoid any risk of electric shock always remove the master plug from the mains before making any electrical connections or any other maintenance intervention on the appliances.



Make sure that all personnel responsible for transport and installation of the appliance are aware of these instructions.



IMPORTANT!

Do not allow R-410A to escape into the atmosphere: R-410A is a fluorinated greenhouse gas, as cited in the Kyoto Protocol, with a Potential Global Warming effect (GWP) = 1975.



DISPOSAL

The symbol on the product or on the packaging indicates that the product must not be considered as normal domestic refuse but it must be taken to an appropriate disposal point for recycling electrical and electronic appliances.

Disposing of this product in the appropriate way avoids causing potentially negative consequences both for the environment and for the health that could occur if the product is not disposed of correctly.

Further information about the recycling of this product can be obtained from your local town hall, your refuse collection service, or in the store at which you bought the product.

This regulation is valid only in EU member states.

1.3 WARNING

The air-conditioner should be used for the exclusive purpose of producing hot or cool air (on demand) for the sole purpose of obtaining a comfortable temperature in the room.

Improper use of the equipment, which may cause injury/damage to persons, property or animals, relieves **OLIMPIA SPLENDID** of any liability.

1.4 LIST OF SUPPLIED COMPONENTS

The supply includes the parts listed in the table below (fig. 1). Before beginning to assemble the unit, make sure all the parts are within easy reach.

- A - Strip of adhesive isolating tape
- B - Air inlet and outlet external grids including chains and kit for installing the grids (n.2)
- C - Internal flanges (2)
- D - Sheet for wall pipes
- E - Kit of screws and anchor bolts
- F - Wall anchoring bracket
- G - Use and maintenance booklets + warranty
- H - Remote control
- I - Paper template to make holes

1.4.1 Storage

Store the packages in a closed room, protected from atmospheric agents and resting on pallets or beams to isolate from the ground.



DO NOT OVERTURN THE PACKAGE.

1.4.2 Receipt and unpacking

The products are packaged by expert personnel using suitable packaging material.

The units are delivered complete and in perfect condition, however we suggest that you perform the following controls of the quality of the shipping service:

- on receiving the goods, check if the package is damaged. If affirmative, accept the goods with reserve, taking photographs of any apparent damage.
- unpack and check the contents against the packing list.
- check that none of the components have been damaged during transport; if they have, inform the forwarder by registered letter with receipt within 3 days of receipt of the goods and enclosing photographic evidence.
Send the same information by fax to **OLIMPIA SPLENDID**.
No complaints will be accepted if made more than 3 days after the delivery of the goods.



Important note:

Keep the packaging at least during the warranty period for any possible delivery of the product to a service centre. Dispose of the packaging in compliance with the regulations concerning refuse disposal.

1.5 UNIT ELEMENTS (fig. 2)

The two units that make up the air-conditioner are packed separately in cartons.

Packaging may be transported per single units, by hand by two authorized persons, or loaded on a trolley, even piling up to a maximum of three packs.

- 1) Air outlet flap
- 2) Suction flap
- 3) Function and alarms display console
- 4) Air intake grid
- 5) Air filters
- 6) Purifying filter
- 7) Active carbon filter
- 8) Lower guard
- 9) Condensate discharge
- 10) Emergency condensate discharge
- 11) Power cable

2

INSTALLATION

2.1 INSTALLATION MODES

To obtain the best results and optimum performance, follow the instructions for correct installation provided in this manual. Failure to follow the instructions and apply the rules indicated may cause malfunction of the appliance and relieves the manufacturer, **OLIMPIA SPLENDID** of any form of guarantee and liability for damages to persons, animals or property.



The electrical system must comply with the regulations and rating data in the technical sheet, with good grounding.

2.1.1 Size and specifications of the room in which to install the air conditioner

Before installing the air conditioner, it is essential to make an accurate calculation of the heat load in summer (and cold load in winter for models with heating pump) at the site of installation.

The more accurate this calculation is made the better the air conditioner will be able to do its job.

When executing the calculations, refer directly to the prevailing standards.

For particularly important applications, we recommend contacting expert heating engineers.

The user should try to limit high heat loads as much as possible as follows: glass doors and windows exposed to many hours of sunlight should be fitted on the inside with curtains or, even better, on the outside with coverings such as Venetian blinds, verandahs, refractive film, etc.). The air-conditioned room must remain closed as long as possible.

Halogen spotlights or other electrical equipment with high power consumption should not be used in the room (toasters, steam irons, hot plates for cooking, etc.).

2.2 CHOOSING THE POSITION OF THE UNIT

The position for installing the unit, to obtain best performance and avoid breakdowns or hazards, must have the following requisites (fig. 3):

- The height of the unit's lower edge from the floor should be at least 100 mm if fixed to the wall in the lowest position.
- If fixed to the wall in the highest position, it should be at least 80 mm from the ceiling.
- The wall on which the inside unit is installed must be sturdy and able to withstand its weight.
- It must be possible to leave room around the unit for any maintenance operations that may be necessary.
- Nothing should be in the way of the air that needs to circulate both on the top air-intake (curtains, plants, furniture) and at the front where the air exits. This could cause air swirls that would inhibit the working efficiency of the unit.



The air conditioner must be installed on a wall that communicates with the outside.



Caution: after determining the best place for installation as described above, check for the absence of other structures or systems (beams, piers, pipes, wires, etc.) at the points where the holes are to be drilled, which would prevent drilling the holes required to install the unit.

Check again to make sure there are no obstacles to air circulation through the holes to be drilled due to plants and their leaves, slats or panelling, blinds, gratings or grids too dense, etc.).



WARNINGS (fig. 4):

- it should not be placed under curtains;
- do not spray water or other liquids of any kind directly on the unit;
- it should not be installed in a position where the air flow can directly strike people in the whereabouts.
- never force the opening of the airflow flap;
- do not place bottles, cans, clothes, flower pots or any other object on top of the air suction flap that would prevent the flap from opening;
- it should not be directly over another appliance (television set, radio, refrigerator, etc.), or over a source of heat.

2.3 UNIT ASSEMBLY

2.3.1 Warning

The maximum length allowed for pipes is 1 m. The pipes must be smooth on the inside, and with a diameter of 202 mm. Pipes cannot be curved or bent.

It is necessary to use the grilles provided, or grilles which keep the same features.

2.3.2 Drilling the wall

Install the unit by drilling two holes (diameter of either 162 mm or 202 mm) in the wall as indicated in the drilling template. The 202-mm holes will ensure best performance and utmost noiselessness.

The UNICO INVERTER unit may be installed in lieu of a UNICO SKY or UNICO STAR unit without changing the position of the existing holes, with the exception of the small hole for condensate drainage. In this case, in order not to penalize performance, remove the insulating material from the air outlet pipe. Drill the wall using the proper tools to facilitate your job and prevent excess damage or disturbance to your client. The best tools for drilling large holes in walls are special drills called core borers with very high twisting torque and adjustable rotating speed depending on the diameter of the hole to be drilled.

To prevent the creation of large amounts of dust and rubble due to drilling, the core borer can be fitted with a vacuum system applied by means of suction cups to the drilling zone. To drill the holes, proceed as follows:
Fasten the drilling template to the wall leaving the necessary space from the ceiling, floor and side walls as shown on the template that may be fixed using adhesive tape.
Use a small drill or punch to mark, with extreme care, the exact centre of each of the holes to be drilled.
Using a core boring head measuring at least 162 mm to drill the two holes for entry and exit of the air.



WARNING: drill the foregoing holes tilted slightly downwards to prevent water from being fed back through the ducts (fig. 5).

Most of the removed material is expelled outwards, therefore make sure that it does not hit any person or object when it falls out. In order to avoid as much as possible outer plaster breaking, it is necessary to proceed carefully with the last part of hole execution, decreasing pressure on core borers.

Next, drill the holes for anchoring the fastening brackets to the wall using as a first option the 4 holes on the ends of the bracket as shown on the drilling template.

If the wall is not very solid, it is advisable to use some extra anchor bolts.
As you can see, the bracket can be fastened in a number of different ways and positions. The majority of the weight of the appliance is to the right side so ensure that fixing is more secure on this side. The anchor bolts provided require holes with a diameter of 10 mm.

In any case, the wall should be inspected carefully to determine the best possible anchorage and type of bolts suitable for particular situations.



WARNING: the manufacturer will not be held liable for any underestimates made in the structural consistency of the anchor prepared by the installer.

Therefore, pay utmost attention to the foregoing operation that could cause serious injury/damage to people/property if carried out incorrectly.

When installing models equipped with heating pump, if no condensate discharge was built into the wall (see paragraph 2.3.3), in order to drain the condensate it will be necessary to drill a hole through the wall in the position shown on the template.

2.3.3 Preparing the condensate discharge

As far as machines equipped with a heating pump are concerned, connect the unit to the condensate discharge pipe (supplied) by coupling it with the specific vent (fig. 6 ref. A) that is on the back of the machine (remove cap B). When the max level is reached, a solenoid valve ensures the condensate will flow out from the internal tray. For cold-only machines, connect the condensate discharge pipe if you intend running the unit at low outdoor temperatures (lower than 23°C).

Since condensate drains by gravity, there must be a minimum slope of at least 3% at every point of the discharge line. Use a rigid or flexible tube having an inside diameter of at least 16 mm.

If the line empties into a sewerage system, install a siphon before the point in which the pipe reaches the main discharge, at least 300 mm below the inlet from the unit (fig. 6).



If the drainpipe drains into a vessel (tank or other container), this container **should not be sealed and the drainpipe should not remain immersed in the water** (see fig. 7).

The hole through which the condensate pipe passes should always slope towards the outside (see fig. 8).

The exact position in which to place the pipe inlet, as compared to the machine, is shown on the drilling template.



CAUTION: make sure, in this case, that the water expelled outward does not damage or disturb persons or property. During the winter this type of drainage may cause sheets of ice to form.

When the condensate drainage is fitted, pay much attention not to compress the rubber hose.

2.3.4 Assembly of the air ducts and external grids

After having drilled the holes, insert the plastic sheet supplied with the conditioner into them.
Since the sheet was made for 202 mm holes, you will have to cut off 130 mm from the long side of the sheet for the 162 mm holes.
The sheets must be 65 mm shorter than the length of the wall.

Roll the sheet and insert it into the hole (fig. 9), **paying attention to the splicing line (fig. 9 ref. A), which must always face upwards.**

Use an ordinary cutter for the foregoing operation (fig. 9).

To position the external grids, proceed as follows:

- Apply the seal (fig. 10 ref. B) to the wall flange (fig. 10 ref. A), ensuring it lines up with the outer edge of the flange as indicated in the figure.
- Fix the two flanges using 2 pegs having a diameter of 6 and check that the two fixing holes are horizontal.
- Fit the small eyelet of the spring, with the long stem, on the cap pin (on both components) (fig. 11).
- Insert the two caps (with spring), on the front part of the external grid, on its two housings, pulling until it clicks (fig. 12) and

- couple the two chains to the large eyelet of the spring.
- Using one hand, grip the two chains connected to the grid.
- Bend the external grids back, gripping them with your free hand where they bend, and insert your fingers inside the single fins (fig. 13).
- Insert your arm into the pipe until the grid protrudes completely outwards.
- Reopen the grid, being careful to keep your fingers inside the fins.
- Turn the grid until the fins are fully horizontal and tilted downwards.
- Pull the chain, tensioning the spring, and couple the chain ring to the pin of the inner flange through which the pipes pass (fig. 14).
- Use hand shears to cut off any excess chain links.



WARNING: use exclusively the supplied grids, or grids with like characteristics.

2.3.5 Preparing the holes on the machine

The unit was built to be paired with 162-mm pipes and, in order to obtain best performance and noiselessness, you should use the 202-mm holes. Configure the unit as follows:

- Use a cutter to punch an opening on the rear cover and remove the covering part (fig. 15 ref. A) so as to create the air passage hole having a diameter of 202 mm.

2.3.6 Fitting the unit on the bracket

After having checked that the fixing bracket is properly anchored to the wall and that the suitable preparatory work - if required - has been carried out for the electrical connections and the condensate drainage, the air-conditioner can be fixed to the wall. Lift it by holding it from the sides of the lower base (see fig. 16).

To facilitate the operation of fastening it to the bracket, tilt it slightly toward you.

To make the electrical connection and fasten the drainpipe, place a wedge between the air conditioner and the wall (see fig. 16).

When you have finished, inspect carefully to make sure there are no fissures at the back of the air conditioner (the insulating gasket must fit firmly against the wall) particularly in the zone where air enters and leaves the machine.

2.3.7 Electric hook-up

The appliance is fitted with a power cord with plug (Y-type connection). If the socket is in proximity to the appliance, simply plug it in.



Before connecting the conditioner, ensure that:

- The power supply voltage and frequency values comply with those indicated on the data plate of the appliance.
- The power supply line is fitted with an efficient earth connection that is appropriately sized for the maximum absorption of the conditioner (minimum cross-section of the cable must be 1.5 mm²).
- The appliance is powered exclusively through a socket that is compatible with the plug supplied.



WARNING: Any replacement of the power cable must be carried out solely by Olimpia Splendid technical support or by similarly qualified personnel.



WARNING: On the power supply line of the appliance there must be an adequate omnipolar disconnection device that complies with the national installation regulations. It is, however, necessary to check that the electrical power supply is equipped with efficient earthing and with adequate protections against overloading and/or short circuits (a type 10 AT delayed fuse or other devices with equivalent functions are recommended).



It is possible to proceed with the electrical connection using a cable embedded into the wall in a position as indicated in the installation template (recommended connection for installing the appliance is to the upper part of the wall).



WARNING: this operation must be performed only by the installer or any similarly qualified personnel and in compliance to the current national regulations.



To prevent the risk of an electric shock it is mandatory to switch off the main switch before performing the electrical connections or any maintenance operation to the appliances.

To perform the electrical connection through a cable embedded into the wall, proceed as follows:

- remove the lower cover (wedged in) (fig. 17 ref. A)
- remove the upper cover (wedged in) (fig. 17 ref. B)
- unscrew the 6 screws that lock the front cover (fig. 18 ref. A)
- remove the front cover (fig. 19)
- remove the cover of the electrical box (fig. 19 ref. A)
- unscrew the cable clamp (fig. 19 ref. B)
- unscrew the cable fixing screws of the terminal strip (fig. 19 ref. C)
- remove the cable
- insert the new cable following the same route

- remove the wooden wedge from behind the unit
- lock the cable's three poles in the terminal strip and tighten the screws (fig. 19 ref. C)
- block the cable with the clamp (fig. 19 ref. B)
- close the protection of the board (fig. 19 ref. A)
- refit the front cover of the machine with the six screws
- refit the two wedged-in covers (upper and lower).



CAUTION: these operations should be performed with the machine already positioned on the bracket. Read the instructions carefully before completely the electric connection.

2.4 TOP/BOTTOM INSTALLATION CONFIGURATION

This unit may be installed either at the bottom of the wall (adjacent to the floor) or at the top (adjacent to the ceiling). The air jet can be modified to optimize air distribution and room well-being by changing the position of the air outlet flap.

Figure 20 refers to a machine configured for installation near the floor in which air flows upwards. The same configuration may also be used to install the unit near the ceiling with the cooling function. This permits to increase the air flow inside the room (Coanda effect). Figure 21 refers to a machine configured for installation near the ceiling in which air flows downwards.



OPERATION TO BE PERFORMED WHEN THE MACHINE IS SWITCHED OFF AND THE POWER SUPPLY IS DISCONNECTED.



CHANGING THE CONFIGURATION OF THE AIR OUTLET FLAP FROM BOTTOM TO TOP OF WALL

- delicately open the air outlet flap
- unhook the flap (side and central hooks on the baffles) (fig. 20)
- remove the pin (fig. 20 ref. A)
- turn the flap 180° (fig. 20)
- insert the pin (fig. 21 ref. A) on the right-hand side of the flap
- insert the flap into the machine by inserting the pin (fig. 21 ref. B) into the top hole that is on the right-hand side in the opening (fig. 21 ref. C), and the flap's left-hand hole on the upper pin that is on the left-hand side in the opening (fig. 21 ref. D).

CHANGING THE CONFIGURATION OF THE AIR OUTLET FLAP FROM TOP TO BOTTOM OF WALL

- delicately open the air outlet flap
- unhook the flap (side and central hooks on the baffles) (fig. 20)
- remove the pin (fig. 20 ref. A)
- turn the flap 180° (fig. 20)
- insert the pin (fig. 21 ref. A) on the right-hand side of the flap
- insert the flap into the machine by inserting the pin (fig. 21 ref. B) into the bottom hole that is on the right-hand side in the opening (fig. 21 ref. C), and the flap's left-hand hole on the lower pin that is on the left-hand side in the opening (fig. 21 ref. D).

After having carried out the mechanical operations to change the air outlet flap, configure the machine's control electronics as follows:

- connect the power supply line
- ensure the machine is in standby (fig. 22 ref. A)
- hold down the display button (fig. 22 ref. H) until an audible signal starts ringing
- CEILING CONFIGURATION: press the display button (fig. 22 ref. H) to select yellow LED C (fig. 22)
- FLOOR CONFIGURATION: press the display button (fig. 22 ref. H) to select green LED D (fig. 22)
- release the display button (fig. 22 ref. H)
- wait a few seconds until the standby configuration is restored (fig. 22 ref. A).



IMPORTANT: EACH TIME THE AIR OUTLET FLAP CONFIGURATION CHANGES, THE RELEVANT ELECTRONIC CONFIGURATION MUST ALSO BE CHANGED.



N.B. the ceiling configuration determines the automatic correction of the heating room temperature, which is equivalent to 3°C.

2.5 TESTS AND TROUBLESHOOTING

Should the air-conditioner stall and issue an alarm signal, refer to the Service Centre which LEDs are blinking in order to simplify their intervention (fig. 22).

LED D: condition active

LED C: timer active

LED B: compressor ON

LED A: indicates the filter may need cleaning

After this operation the LED must be switched off manually as indicated in section 2.6.1

2.5.1 Evacuating condensate water during an emergency

If a malfunction occurs in the condensation water drain system, the air conditioner stops working and signals the alarm status with the flashing of the first and second LEDs from the left (green / orange).

To enable the air conditioner to work temporarily until the service personnel arrive, you can drain the water out by following these simple instructions:

- remove the lower cover (fig. 23 ref. A)
- remove the cap (fig. 23 ref. B) after having placed a good-sized container underneath it (at least 5-liter capacity) to collect the water (see fig. 23)
- after having cleared the fault, the service personnel will close the evacuation pipe.

2.6 ROUTINE MAINTENANCE

The air conditioner that you have purchased has been designed to reduce routine maintenance operations to a minimum. These operations involve solely the cleaning operations outlined below:

- Cleaning or washing of the ambient air filter every 2 weeks or every time the relative red LED lights up (this can be done by the user, see user manual).
- Cleaning of the condensing battery and cleaning of the condensate management system. These operations must be carried out by skilled technicians on a regular basis that will depend on the place of installation and intensity of use. Depending on the quantity of dirt, the unit can be cleaned dry (by using a battery compressor and bowl and cleaning the fins with a soft brush taking care not to deform them) or more thoroughly using dedicated detergents.

Before you leave the site of installation you should gather up all packing material and use a damp cloth to remove any traces of dust that may have deposited on the machine during assembly (fig. 24).

These operations, though certainly not essential, have a beneficial effect as they enhance the professional image of the installer in the eyes of the client.

To prevent unnecessary calls by the user, before you leave the site of installation it is also a good idea to:

- Explain the contents of the Instruction Manual to the user.
- Show the user how to clean the filter.

2.6.1 Cleaning the air filter



OPERATION TO BE PERFORMED WHEN THE MACHINE IS SWITCHED OFF AND THE POWER SUPPLY IS DISCONNECTED.

To ensure effective internal air filtration and satisfactory operation of your air conditioner, the air filter has to be cleaned periodically.

The air filter is at the top of the unit.

Removing the filter:

- turn off the unit and wait until the suction flap has closed
- manually lift the air suction flap (fig. 25)
- lift the front part of the filter (fig. 25 ref. A)
- pull slightly to remove the edge from the upper grid (fig. 25 ref. B)
- remove the two supplementary filters (green purifying filter ref. B and black active carbon filter ref. C) from the filter unit (fig. 27 ref. A)
- wash and dry all the filters
- fit the active carbon filter (black) (fig. 26 ref. C) on the filter unit (fig. 26 ref. A) and lock it to the specific tongues (fig. 26 ref. D)
- fit the purifying filter (green) (fig. 26 ref. B) on the first pin that is on the filter unit (fig. 26 ref. E), pull it slightly and lock it on the other two pins (fig. 26 ref. F)
- refit the filter unit by inserting the rear edge (fig. 27 ref. B) into the grid (fig. 27 ref. A)
- lower the front edge (fig. 27 ref. C) on the machine
- manually close the suction flap.

To deactivate LED A (if on), after having powered and started the appliance, press the micro key on the signal console (fig. 22 ref. H) with a pointed object for a brief instant. By doing so, the signal related to the filter cleaning requirement is reset.



WARNING: in order to avoid damaging the unit, the manually open and close the air suction flap very carefully, avoiding abrupt movements that could damage the plastic and mechanical parts.



WARNING: after having cleaned the filters, the air suction flap might stop in a wrong position on turning on the unit again. In this case:

- turn off the unit
- manually move the suction flap to closed position
- cut off power supply (disconnect the power cable)
- wait about 30 seconds
- plug in the power cable
- turn on the unit.

3.1 WARNINGS



The installation and electrical connection of the air conditioner should be carried out by specialized personnel who possess the requisites set forth by law. The installation instructions are contained in the appropriate paragraph of this manual.



No structural object (furniture, curtains, plants, leaves, blinds, etc.) should ever obstruct the normal flow of air from either the internal or external gratings.



Never lean or, worse yet, sit on the casing of the air conditioner as this could cause serious damage to the external parts.



Do not move the air outlet flap by hand. Always use the remote control to adjust baffle position.



If the unit leaks water, switch it off immediately and disconnect it from the power mains. Call the nearest service centre.



When the air conditioner is heating, it has to periodically eliminate any ice that could form on the external battery. While it is doing this, the machine keeps running but does not heat the room. This lasts for a brief period of time, from 3 to a maximum of 10 minutes.



The air conditioner must not be installed in rooms where explosive gasses develop or where there are conditions of heat and humidity beyond the maximum limits indicated in the installation manual.



Clean the air filter periodically, as described in the specific paragraph.

3.1.1 Description of the warning panel (fig. 22)

- G) Transparent area in which the signal is received from the remote control.
- LED D) Green LED that indicates the machine is running (when the machine is in standby this light is off).
- LED C) Yellow LED signals activation of the programming switch on and/or switch off.
- LED B) Green LED that indicates the switching on of the cooling compressor.
- LED A) Red LED that indicates the air filter must be cleaned.
- H) Service micro-button (RESET)

3.2 MANAGING THE UNIT WITH THE REMOTE CONTROL

3.2.1 Remote control



The remote control supplied with the air conditioner is designed to be extremely sturdy and to ensure excellent performance in use, but it should nevertheless be handled with some care.

For example, do not:

- leave it out in the rain, spill water on its keyboard or drop it into water
- subject it to impacts or drop it onto hard surfaces
- leave it exposed to direct sunlight
- place obstacles between the remote control and the air conditioner while using it.

Furthermore:

- if other devices operated by remote control (TV, radio, stereo systems, etc.) are located in the same room as the air conditioner, there may be interference,
- electronic and fluorescent lighting may interfere with communications between the remote control and the air conditioner,
- remove the batteries in case of prolonged disuse of the remote control.

3.2.2 Fitting the batteries

The remote control exclusively requires 2 dry LR03 1.5 V batteries (not included with the supply). Used batteries should be disposed of solely by depositing them into the appropriate collection points arranged by the Local Authorities specifically for this type of waste.



Replace both batteries at the same time.

To insert the batteries remove the spring-latch cover on the back of the remote control. The batteries have to be inserted according to the positive and negative pole markings in the bottom of the battery compartment. Close the spring-latch cover after inserting the batteries.

3.3 REMOTE CONTROL

The remote control is the interface between the user and the air conditioner. It is therefore particularly important to familiarize yourself with the parts of the remote control that relate to this interface.



All the references indicated in the following paragraphs refer to figure 29 on page 8 (unless otherwise specified).

3.3.1 Description of the remote control

Buttons (fig. 29): used to set or bring up machine functions.

- T1** ON/OFF (standby).
- T2** ECONOMY key.
- T3** Night well-being mode.
- T4** Operating mode selector.
- T5** Fan speed selector.
- T6** Button for setting timer and programs.
- T7** Button for increasing (+) or decreasing (-) the temperature/time settings.
- T8** Button for activating the FREE COOLING air change system (not available in this model).
- T9** Movable baffle adjustment On/Off button.
- T10** Reset button.
- T11** Program start button.

Display (fig. 29): shows the operating state and the values of the settings being carried out.

- D1** Fan speed or automatic operating mode indicator (AUTO).
- D2** Heating.
- D3** Cooling.
- D4** Dehumidifier only.
- D5** Air change activation (not available in this model).
- D6** Night operation switch.
- D7** Automatic operation switch.
- D8** First operating program switch.
- D9** Second operating program switch.
- D10** Temperature indicator (thermometer) or time indicator (H/M).
- D11** ECO activation of the economy function

The remote control is also equipped with a sliding cover that can be positioned so as to permit access only to the ON/OFF, ECONOMY MODE and NIGHT MODE buttons.

3.3.2 Main switch-on and running management

To manage the appliance with the remote control, it will be necessary to have activated the main switch which is included on the electrical power supply line (the technician that installed the appliance could offer more details regarding the position), or insert the power plug of the appliance into the socket of the system.

The machine is fitted with a power switch (fig. 28 ref. A) located below the lower safety guard (fig. 28 ref. B); to run it must be in "I" position.

Once these operations have been carried out, the machine may be regulated using the remote control.

In order to transmit commands to the indoor unit, point the front of the remote control toward the unit's control panel.

The device emits a beep when it receives a command.

The maximum distance for transmission of commands is about 8 meters.

3.3.3 Turning the unit ON/OFF (button T1)

Use this button T1 to turn the system off (standby) or on.

Since the machine's control system has a memory, no setting will not be lost when it is turned off.

This button serves to switch the air conditioner on or off for brief periods of time.



In case of prolonged stop of the machine, it must be deactivated turning the main switch off or unplugging the machine from the mains.

3.3.4 ECO key (button T2)

The energy saving function is activated through this button T2 and the switching on of the **ECO** icon remote control on the display, which automatically optimizes machine running.

3.3.5 Cooling

When used in this mode, the air conditioner dehumidifies and cools the room.

Activate this mode by pressing button T4 (*Run mode selector*) until the snowflake symbol D3 is displayed.

In this run mode, the required temperature and fan speed can be set.

After three minutes (as a maximum) from activation in this operating mode the compressor will start and the appliance starts emitting cold air.

Start up of the compressor is indicated by the lighting up of the green LED B (fig. 22) positioned on the console.

3.3.6 Dehumidification only

When used in this mode, the air conditioner eliminates the humidity in the room. This function can be extremely useful between seasons, particularly on rainy days when the temperature is not uncomfortable but the excess humidity feels unpleasant.

In this mode, both room temperature and fan speed settings are ignored, which correspond to minimum.

As such, no temperature and fan speed indications are displayed.

Activate this mode by pressing button T4 (*Run mode selector*) until the droplet symbol D4 and automatic ventilation symbol (D1) are displayed.

In this operating mode it is normal for the air conditioner to function intermittently.

3.3.7 Ventilation only

When used in this mode the air conditioner does not perform any action with regard to temperature and air humidity in the room.

Activate this mode by pressing button T4 (*Run mode selector*) until the fan symbol D1 is displayed.

At this stage you can select the fan speed (see paragraph 3.3.11).

3.3.8 Well-being function (automatic)

The machine's temperature is automatically regulated according to the room's temperature. The fan speed is also automatically regulated according to the set temperature (except in dehumidification mode).

Activate this mode by pressing button T4 (*Run mode selector*) until the symbol D7 is displayed.

3.3.9 Heating (only models fitted with heating pump)

When used in this mode the air conditioner heats the room. This function is only available on models with a heating pump (HP).

Activate this mode by pressing button T4 (*Run mode selector*) until the sun symbol D2 is displayed.

In this run mode, the required temperature and fan speed can be set. After three minutes (maximum time) the compressor should start and the air conditioner starts heating the room. The start of the compressor can be checked through the lighting of the relevant green LED located on the console.



NOTE: the air conditioner has to defrost its battery periodically. during this operation the air conditioner does not heat the room, though its internal parts remain on except for the room air fan. when the outdoor temperature is very low, there may be a slight delay for passage from the minimum to the medium or maximum speed from when the command is sent to the machine with the remote control.

Like delays might occur on activating the swinging function of the mobile baffle.

After having turned off the unit, the internal fan runs 60 seconds more. Then it stops and both air flaps close.

3.3.10 Checking airflow direction

By pressing button T9 it is possible to activate/deactivate the continuous swing of the mobile air outlet baffle. When the continual swing is activated, one further press of button T9 will block the baffle so that the desired vertical direction of the air flow is obtained.



IMPORTANT: Movement of the mobile baffle must never be forced manually.

3.3.11 Checking fan speed

Fan speed is checked by button T5. Pressing this button several times will change the speed in this order: Low, Medium, High and Automatic.

The higher the speed setting, the greater the output of the air conditioner but also the louder its operation. By setting the Automatic mode, the onboard microprocessor adjusts the automatic speed. The higher the difference between the room temperature detected and the temperature set, the higher the speed.

As the room temperature nears the setting, fan speed is reduced automatically.

In dehumidification mode, it is not possible to control the speed as the appliance can only operate exclusively at low speed.

3.3.12 Night well-being key

Press the *night well-being* T3 button to obtain several results, specifically:

- Gradual increase of the set cooling temperature.
- Gradual decrease of the temperature set for heating (only HP models).
- Decrease of the unit's noise level.
- Savings on night-time consumption of electricity.

In order to activate the *Night well-being key press button T3* after having selected the required operating mode through button T4 and having set the required temperature through button T7.

Ideally, you should start night well-being mode operation just before you fall asleep.

In cooling, the set temperature is maintained for one hour after activating the night-time comfort button. During the next two hours the setting increases gradually, whilst the running of the fan is set to low speed. After the second hour, the temperature and fan speed settings do not change any longer.

In heating mode, the set temperature is held for one hour after starting Night well-being mode operation.

During the next two hours the setting decreases gradually, whilst the running of the fan is set to low speed.

After the second hour, the temperature and fan speed settings do not change any longer.

The '*night well-being*' key is not available when the unit operates in dehumidification and ventilation mode.

The *night well-being mode button* may be disabled at any time (ideally when you wake up in the morning) by pressing button T3 again. At this stage the temperature and fan speed settings made prior to starting Night well-being mode operation go back into effect.

3.3.13 Setting the operating programs

The air conditioner logic provides the user with a choice of two operating programs that can be set to start and stop at programmed times, for example you might want the air conditioner to start shortly before you return home so that it is cool when you get there. To use these functions it is first necessary to set the exact time on the remote control and then set the time for the programs to start.

3.3.14 Setting the exact time

Proceed as follows to set the exact time:

- a) Press button T6 (*Time and Program Setting*), as many times as necessary to display the hour indication **H** (D10).
- b) Press the toggle button T7 to increase or decrease the displayed hour until it matches the exact time.
- c) Press button T6 again to display the minutes indication **M** (D10).
- d) Press the toggle button T7 to increase or decrease the displayed minutes until it shows the exact time in minutes.

3.3.15 Setting the times of the 1st and 2nd the operating programs (PROGR. 1 and PROGR. 2)

To set the times for starting and stopping the two air conditioner programs, proceed as follows:

- a) Press button T6 (*Time and Program Setting*), as many times as necessary to display the indication **1** (Time to start the 1st program).
- b) Press the toggle button T7 to increase or decrease the display of the time when you want program 1 to start. Every time you press one end of the toggle button the time increases or decreases by 30 minutes.
- c) Press button T6 (*Time and Program Setting*) once again to display the indication **1** (Time to stop the 1st program).
- d) Press the toggle button T7 to increase or decrease the indication of the time when you want program 1 to stop. Every time you press one end of the toggle button the time increases or decreases by 30 minutes.
- e) Press button T6 (*Time and Program Setting*) once again to display the indication **2** (Time to start the 2nd program).
- f) Press the toggle button T7 to increase or decrease the display of the time when you want program 2 to start. Every time you press one end of the toggle button the time setting increases or decreases by 30 minutes.
- g) Press button T6 (*Time and Program Setting*) once again to display the indication **2** (Time to stop the 2nd program).
- h) Press the toggle button T7 to increase or decrease the indication of the time when you want program 2 to stop. Every time you press one end of the toggle button the time increases or decreases by 30 minutes.
- i) To return to the routine operating mode just press the button T6 as many times as necessary to clear the relevant indications from the display.

3.3.16 Starting and stopping the operating programs

After having made the settings for the operating programs, they can be used or not, as needed.

Either or both of the programs can be used.

In particular, each time you press the button T11 (*Program activation*), the situation changes as follows:

Use of Program no. 1 only.

Use of Program no. 2 only.

Use of Programs 1 and 2.

Disuse of both programs.

3.3.17 Resetting all remote control functions

Press the button T10 to reset all the remote control settings.

By doing so all of the settings of the timer are cancelled and the remote control restores all of the default settings.

Furthermore, by pressing button T10, all of the symbols indicated in fig. 29 will appear on the display, thus making it possible to check the integrity of the display itself.

3.3.18 Managing the unit if the remote control is not available

If you cannot find the remote control, if it is faulty or the batteries are flat, the unit can work in Automatic mode only.

Use a pointed object to press the microswitch located underneath the hole on the control panel.

To switch the air-conditioner off, press the microswitch again.

To restore routing operations in the remote control, you need only issue any command once the remote control is available again.

3.4 ENERGY SAVING ADVICE

- Always keep the filters clean (see chapter on maintenance and cleaning).
- Keep the doors and windows closed in the air-conditioned rooms.
- Keep sunlight out of the room by using curtains, lowering the shades or closing the shutters.
- Do not obstruct the air flow channels (both inlet and outlet) of the unit; apart from preventing the optimal performance of the system, this would also jeopardise correct operating and could cause irreparable damage to the unit.

3.5 DIAGNOSIS OF THE PROBLEMS

It is important for the User to distinguish between functional problems and anomalies in relation to the behaviour of the appliance as foreseen for its normal operation. Furthermore, the most common problems may easily be solved through simple operations on behalf of the User (See paragraph: Anomalies and solutions), while for all of the other anomalies it is necessary to contact the Olimpia Splendid Service Centre.



WARNING: Please remember that any attempt to repair the appliance by unauthorised personnel will immediately invalidate any form of guarantee.

3.5.1 Functional aspects not to be interpreted as problems

- The compressor does not start up again immediately after a stop (it takes about three minutes to start again). In the operating logic of the appliance a delay between a compressor stop and its successive restart has been included, so that the compressor itself is protected against activations that are too frequent.
- During the heating operation of the heat pump appliances, the flow of hot air may occur some minutes after activation of the compressor.
Should the fan start at the same time as the compressor, for the first few minutes it would emit cold air into the room (and this could bother the occupants) since the unit has not yet reached steady running conditions.

3.5.2 Troubleshooting



In case of malfunctions, check the following table.

If the problem persists after the suggested checks and controls, contact the authorised technical service.

FAULTS	POSSIBLE CAUSES	SOLUTIONS
The unit does not turn on	<ul style="list-style-type: none"> • No power supply The power switch is in "0" position • Remote control batteries are flat 	<ul style="list-style-type: none"> • Check that mains power is present (by turning on a light for instance). • Check if the master switch is closed or if a fuse is burnt (in this case replace the fuse). If there is a magnetothermal circuit breaker instead of the master switch, check if it tripped (if it did, rearm it). Should the problem occur again, contact the Service Center at once and do not attempt to run the unit. • Move the power switch to "1" position (fig. 28 ref. A). • If the batteries are flat, you will notice that no messages are displayed and that the unit's reception confirmation sound is missing when you try to issue any command to it. In this case replace the batteries.
The unit does not cool or heat adequately	<ul style="list-style-type: none"> • The temperature set on the remote control is either too high or too low (when using the heating pump unit). • The air filter has been blocked before the respective cleaning LED was switched on. • Indoor or outdoor air flow obstacles are present. • The heating/cooling load has increased (for example a door or a window was left open or equipment that dissipates a large amount of heat was installed in the same room); 	<ul style="list-style-type: none"> • Check the temperature setting on the remote control and correct it if need be. • Check the air filter and clean it if necessary. • Remove anything that might clog the air flows.

3.5.3 Specifications

For the technical data listed below, consult the characteristic data plate applied to the product

- Power supply voltage
- Maximum power absorbed
- Maximum current absorbed
- Coolant power
- Coolant gas
- Protection rating of the containers
- Max working pressure

Dimensions (W x H x D) mm 902x516x229
 Weight (without packing) kg 39

OPERATIONAL LIMITS	Internal ambient temp.	Outside ambient temp.
Maximum operating temperature in cooling mode	DB 35°C - WB 24°C	DB 43°C - WB 32°C
Minimum operating temperature in cooling mode	DB 18°C	DB -10°C
Maximum operating temperatures in heating	DB 27°C	DB 24°C - WB 18°C
Minimum operating temperatures in heating	-	DB -15°C



www.olimpiasplendid.it
info@olimpiasplendid.it

I dati tecnici e le caratteristiche estetiche dei prodotti possono subire cambiamenti. Olimpia Splendid si riserva di modificarli in ogni momento senza preavviso.